

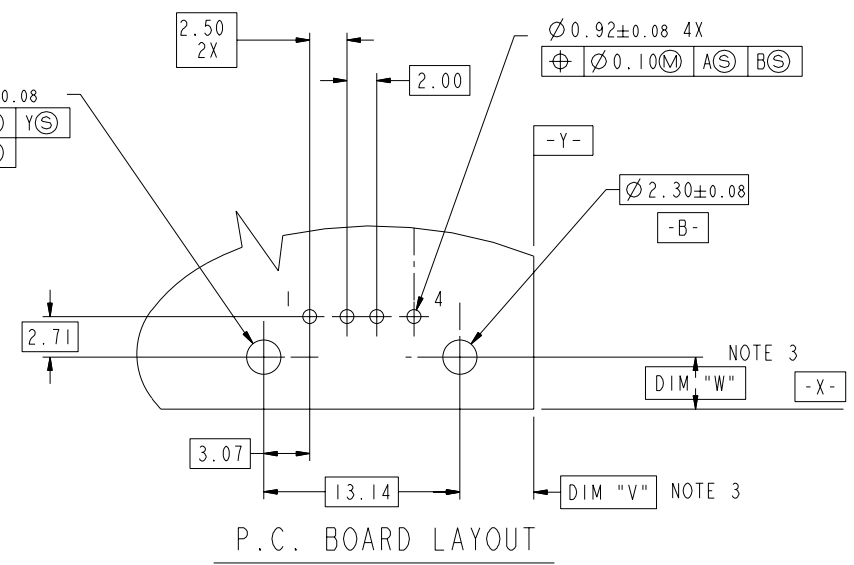

Copyright FCI.

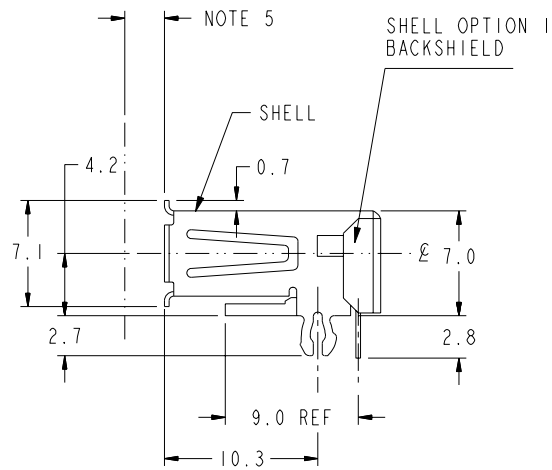
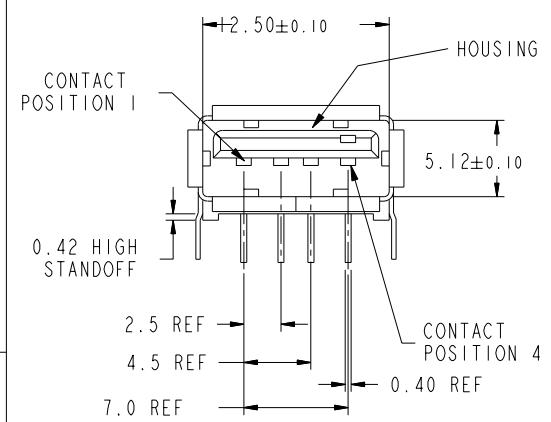
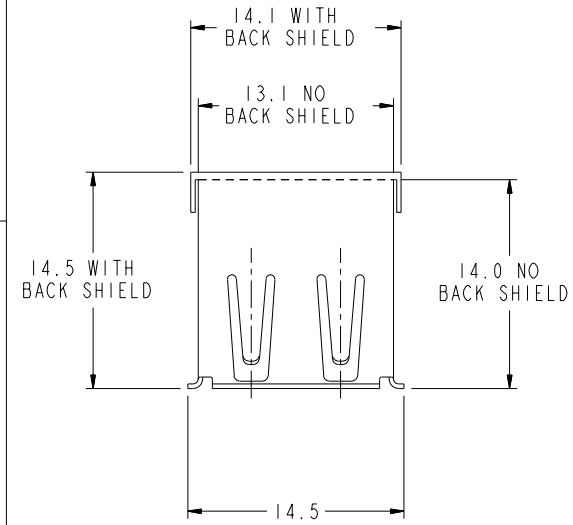

- NOTES:
- MATERIAL:  
CONTACTS: COPPER ALLOY  
SHELL: COPPER ALLOY  
HOUSING: UL 94V-0 RATED THERMOPLASTIC;
  - PLATING:  
CONTACTS: SEE PRODUCT NUMBER CODE  
SHELL: SEE PRODUCT NUMBER CODE;
  - DATUM AND BASIC DIMENSIONS ESTABLISHED BY CUSTOMER;
  - RECOMMENDED PC BOARD THICKNESS OF 1.57mm (EXCEPT STYLE 5 1.20mm)
  - 2.67mm MAXIMUM PANEL THICKNESS IF MOUNTED BEHIND PANEL;
  - CONTACT PLATING CODE OPTION 1 DOES NOT MEET THE PLATING SPECIFIED PER UNIVERSAL SERIAL BUS SPECIFICATION REVISION 1.0;
  - PRODUCT SPEC GS-12-095 & PACKAGING SPEC GS-14-393;
  - COMPLIED WITH USB 2.0 & TID NUMBER 60000204;
  - 87520-1010XX, -1012XX, 3010XX, -3012XX, -5010XX, -6010XX AND -7010XXLF DURABILITY MET 5000 CYCLES THE OTHER DASH NUMBER MEET USB 2.0 DURABILITY 1500 CYCLES.  
(TO BE CONTINUED)

rev	ecn no	dr	date
AJ	N09-0133	R.B	04/28/2009
AF	N07-0176	WG	07/31/07
AG	N08-0012	R.B	2008/01/23
AH	N08-0238	R.B	2008/11/03

www.fciconnect.com		surface	tolerance std	projection	MM
		ANGULAR	LINEAR	size	Scale
		0° ±3°	0.x ±0.3	A4	4.000
			0.xx ±0.2	ECN	
			0.xxx ±	Spec ref	
Dr FUSSELMAN 3/1/96		Product family		Spec ref	
Eng J. DAVID 3/1/96		Product family		Spec ref	
Chr J. DAVID 6/5/96		Product family		Spec ref	
Appr J. DAVID 6/5/96		Product family		Spec ref	
FCI TITLE USB RECEPTACLE			dwg no 87520		Rev. AJ
catalog no			CUSTOMER		sheet 1 of 3

REV F - 2006-04-11

PRODUCT NUMBER CODE

87520- X X X X X P X LF

BASE PRODUCT NUMBER \_\_\_\_\_

HOUSING COLOR AND SHELL PLATING OPTIONS  
 0 - WHITE+SHELL TIN & NICKEL PLATING  
 1 - BLACK+SHELL TIN & NICKEL PLATING  
 2 - WHITE+SHELL NICKEL PLATING ONLY  
 3 - BLACK+SHELL NICKEL PLATING ONLY  
 4 - WHITE FR50 + SHELL TIN & NICKEL PLATING FOR NON LEAD FREE P/N'S  
 CHANGE WHITE FR50 TO WHITE PA46 FOR LEAD FREE P/N'S  
 5 - BLACK NYLON 66 + SHELL TIN & NICKEL PLATING FOR NON LEAD FREE P/N'S  
 CHANGE BLACK NYLON 66 TO BLACK PA46 FOR LEAD FREE P/N'S  
 6 - WHITE FR50+SHELL TIN & NICKEL PLATING FOR NON LEAD FREE P/N'S  
 CHANGE WHITE FR50 TO WHITE PA46 FOR LEAD FREE P/N'S  
 7 - WHITE PA46+SHELL TIN & NICKEL PLATING

SHELL TYPE OPTION  
 0 - NO BACK SHIELD, SEE STYLE 1 FOR DURABILITY 1500 CYCLES  
 SEE STYLE 4 FOR DURABILITY 5000 CYCLES  
 1 - BACK SHIELD, SEE STYLE 2  
 2 - PARTIAL BACK SHIELD, SEE STYLE 3  
 3 - NO BACK SHIELD, SEE STYLE 4 WITH HIGH PERFORMANCE MATERIAL  
 FOR DURABILITY 12,000 CYCLES, NI PLATING ONLY

MOUNTING HOLE OPTIONS  
 1 - NONE

TERMINAL PLATING OPTION  
 0 - 1.25um Ni UNDERPLATE  
 0.76um GXT CONTACT AREA  
 2.50um TIN/LEAD TAIL AREA FOR P/N'S  
 2 - 1.25um Ni UNDERPLATE  
 0.76um /30u" GOLD CONTACT AREA  
 2.50um TIN/LEAD TAIL AREA FOR P/N'S

PACKAGING OPTIONS  
 A - TAPE AND REEL  
 B - TUBES

DATE CODE \_\_\_\_\_

SPECIAL OPTION:  
 S: PANASONIC ONLY  
 B: FOR 1.20mm THICKNESS PCB

LEAD FREE OPTION  
 P/N'S WITH SUFFIX "LF" MEAN LEAD FREE PRODUCT  
 FOR LEAD FREE P/N, CHANGE ALL ORIGINAL TIN/LEAD PLATING TO PURE TIN PLATING

AVAILABLE PART NUMBER LIST

- 87520-0010XXLF
- 87520-0012XXLF
- 87520-0210XXLF
- 87520-1010XXLF
- 87520-1012XXLF
- 87520-0110XXLF
- 87520-0112XXLF
- 87520-1110XXLF
- 87520-1112XXLF
- 87520-2010XXLF
- 87520-2012XXLF
- 87520-2110XXLF
- 87520-2112XXLF
- 87520-2210XXLF
- 87520-3010XXLF
- 87520-3012XXLF
- 87520-3110XXLF
- 87520-3112XXLF
- 87520-4010XXLF
- 87520-4110XXLF
- 87520-5010XXLF/5010XXSLF
- 87520-5110XXLF
- 87520-6010XXLF
- 87520-7010XXSLF
- 87520-3010APBLF
- 87520-3S10XPLF
- 87520-3S12XPLF
- 87520-3S10XPBLF
- 87520-3S12XPBLF

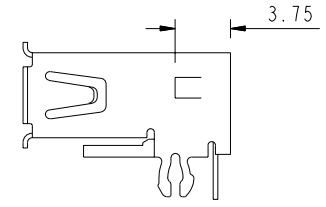

STYLE 1 WITHOUT BACK SHELL

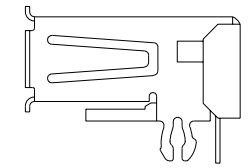

STYLE 2 WITH BACK SHELL

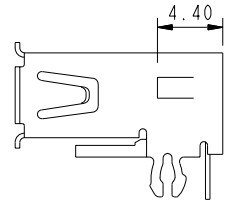

STYLE 4 WITHOUT BACK SHELL

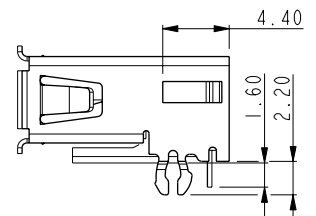

STYLE 5 WITHOUT BACK SHELL FOR 1.20mm THICKNESS PCB

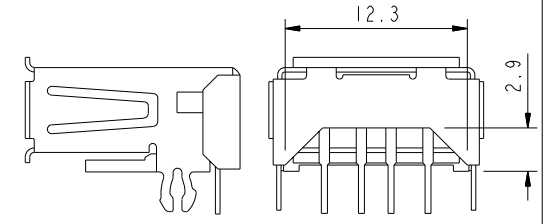

STYLE 3 WITH PARTIAL BACK SHELL

- (CONTINUED)
10. PACKING STANDARD GS-14-920 WILL BE APPLIED FOR LEAD FREE P/N'S;
  11. FOR LEAD FREE P/N, THE PRODUCT MEET EUROPEAN UNION DIRECTIVES AND OTHER COUNTRY REGULATION AS DESCRIBED IN GS-22-008;
  12. THE HOUSING WILL WITHSTAND EXPOSURE TO 260°C PEAK TEMPERATURE FOR 40 SECONDS IN A CONVECTION, INFRO-RED OR VAPOR PHASE REFLOW OVEN;
  13. 87520-1010XXLF/-3010XXLF/-5010XXLF CAN WITHSTAND 2Amps CURRENT EITHER PARALLEL OR SERIALS (TESTING PLUG WITH 20 AWG WIRE);
  14. THE PRODUCT CAN BE USED FOR PIP PROCESS.

- FOR 87520-1010XXLF  
 -1012XXLF  
 -3010XXLF  
 -3012XXLF  
 -5012XXLF  
 -6010XXLF  
 -7010XXSLF  
 -3S10XPLF  
 -3S12XPLF

www.fciconnect.com		surface	tolerance std	projection	MM
		✓		⊕	←
		TOLERANCES UNLESS OTHERWISE SPECIFIED			
Dr	FUSSELMAN	3/1/96	ANGULAR	0.X	±0.3
Eng	J. DAVID	3/1/96	LINEAR	0.XX	±0.2
Chr	J. DAVID	6/5/96	0° ±3°	0.XXX	±
Appr	J. DAVID	6/5/96	Product family		Spec ref
FCI		USB REECEPTACLE		dwg no	87520
		USB			Rev. AJ
		catalog no		CUSTOMER	sheet 2 of 3



Copyright FCI.

PART NUMBER
87520-3010APBLF
87520-3S10XPBLF
87520-3S12XPBLF

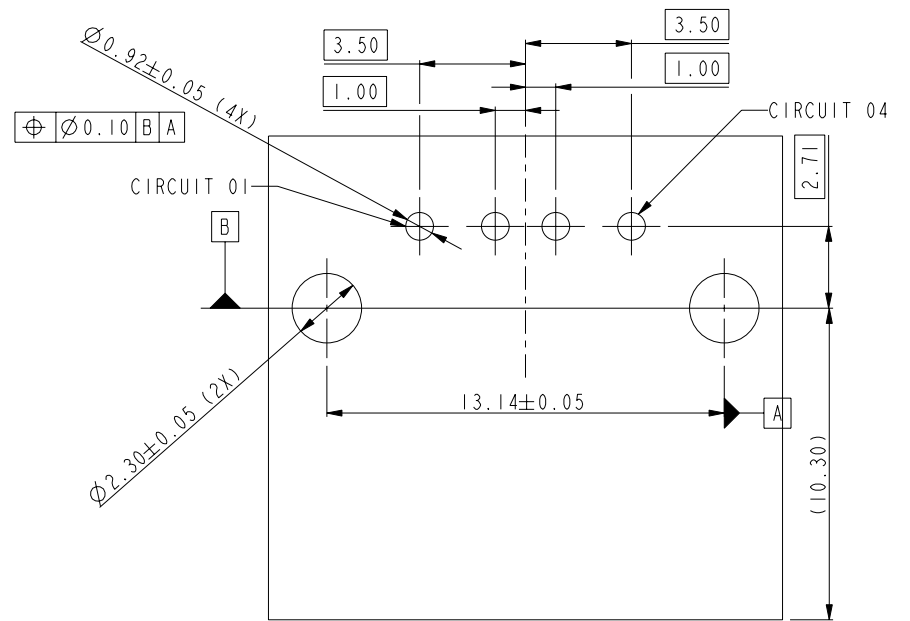
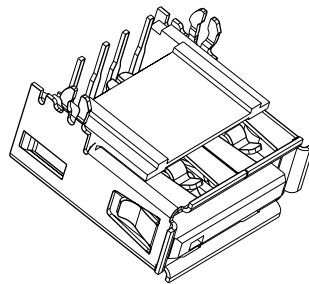
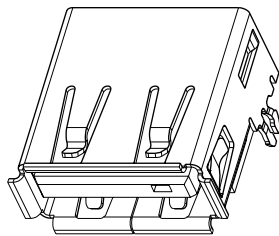
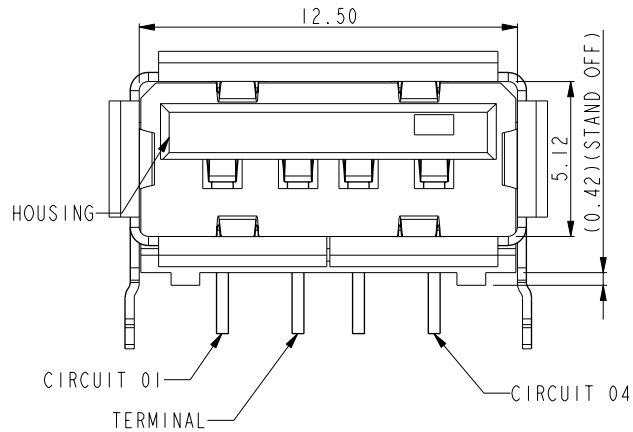
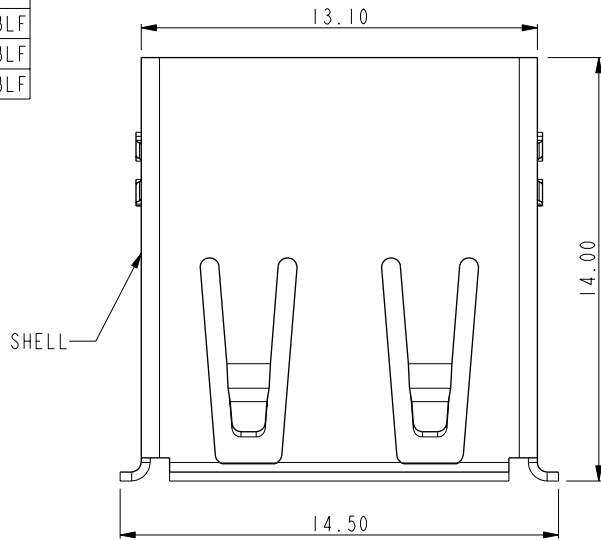

RECOMMENDED PCB LAYOUT  
COMPONENT SIDE

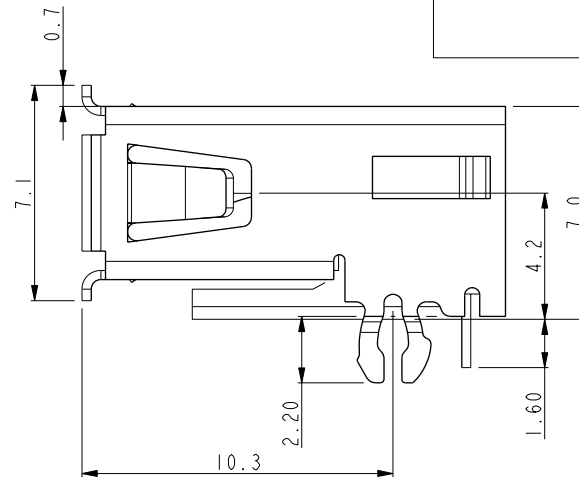

www.fciconnect.com		surface	✓	tolerance std		projection	MM
		TOLERANCES UNLESS OTHERWISE SPECIFIED				← →	
Dr	FUSSELMAN	3/1/96	ANGULAR	LINEAR	0.X	±0.3	size A4
Eng	J. DAVID	3/1/96			0.XX	±0.2	
Chr	J. DAVID	6/5/96	0°	±3°	0.XXX	±	ECN
Appr	J. DAVID	6/5/96	Product family			Spec ref	
		title USB RECEPTACLE			dwg no 87520		Rev. AJ
		catalog no			CUSTOMER		sheet 3 of 3