

PRODUCT NO	PLATING
63429-1Y2	0.38 μ m/15 μ " Au CONTACT. Au FLASH ALL OVER 1.27 μ m/50 μ " Ni
63429-2Y2	0.76 μ m/30 μ " Au CONTACT. Au FLASH ALL OVER 1.27 μ m/50 μ " Ni
63429-3Y2	2.54 μ m/100 μ " TIN/LEAD OVER 1.27 μ m/50 μ " Ni
63429-4Y2	0.08 μ m/3 μ " Au FLASH OVER 1.27 μ m/50 μ " Ni

PRODUCT NO	PLATING
63429-1Y2LF SEE NOTE 6	0.38 μ m/15 μ " Au CONTACT. Au FLASH ALL OVER 1.27 μ m/50 μ " Ni
63429-2Y2LF SEE NOTE 6	0.76 μ m/30 μ " Au CONTACT. Au FLASH ALL OVER 1.27 μ m/50 μ " Ni
63429-4Y2LF SEE NOTE 6	0.08 μ m/3 μ " Au FLASH OVER 1.27 μ m/50 μ " Ni

Y	HSG COLOR	HOUSING MATERIAL $\triangle G$
Y = 0	WHITE	30% GLASS FILLED POLYESTER (SEE NOTE 4)
Y = 1	BLACK	30% GLASS FILLED POLYESTER (SEE NOTE 4)
Y = 2	YELLOW	30% GLASS FILLED POLYESTER (SEE NOTE 4)
Y = 3	BLUE	30% GLASS FILLED POLYESTER (SEE NOTE 4)
Y = 4	BLACK	30% GLASS FILLED LCP (SEE NOTE 5)

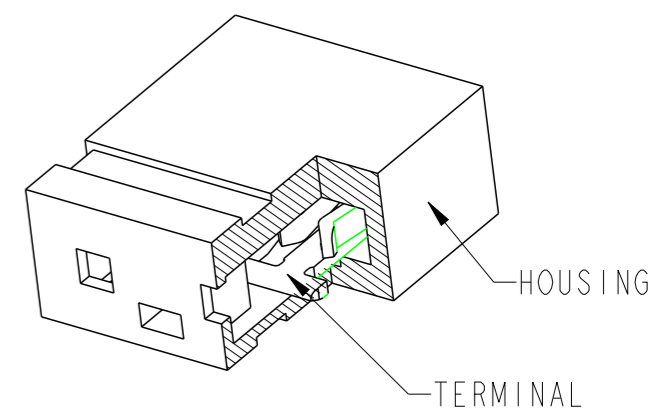

- NOTE:
- $\triangle G$ 1. MATERIAL HOUSING & COLOR: REFER TO TABLE. FLAME RETARDANT PER UL 94V-0
TERMINAL : PHOSPHOR BRONZE
 - 2. PLATING : REFER TO TABLE
 - 3. TECHNICAL REQUIREMENTS:
INSERTION FORCE : 12 NEWTONS (2.7 LB) MAX. PER CONNECTOR.
WITHDRAWL FORCE : 2 NEWTONS (0.45 LB) MIN. PER CONNECTOR.
(MATE WITH 0.635MM SQ. PIN 2.54MM PITCH HEADER)
 - 4. THE HOUSING WILL WITHSTAND EXPOSURE TO 200°C PEAK TEMPERATURE FOR 10 SECONDS IN A CONVECTION, INFRA-RED OR VAPOR PHASE REFLOW OVEN.
 - $\triangle G$ 5. THE HOUSING WILL WITHSTAND EXPOSURE TO 260°C PEAK TEMPERATURE FOR 10 SECONDS IN A CONVECTION, INFRA-RED OR VAPOR PHASE REFLOW OVEN.
 - 6. THIS PRODUCT MEETS EUROPEAN UNION DIRECTIVES AND OTHER COUNTRY REGULATIONS AS DESCRIBED IN GS-22-008.
 - $\triangle G$ 7. A $\triangle G$ SYMBOL WILL BE NEXT TO ANY DIMENSION, VIEW OR NOTE WHICH HAS BEEN MODIFIED WITH THE CURRENT DRAWING REVISION.

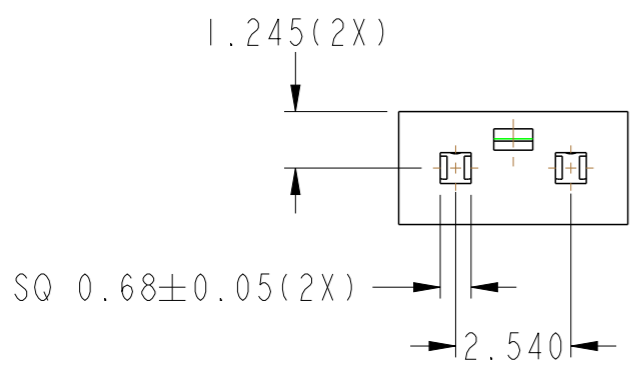
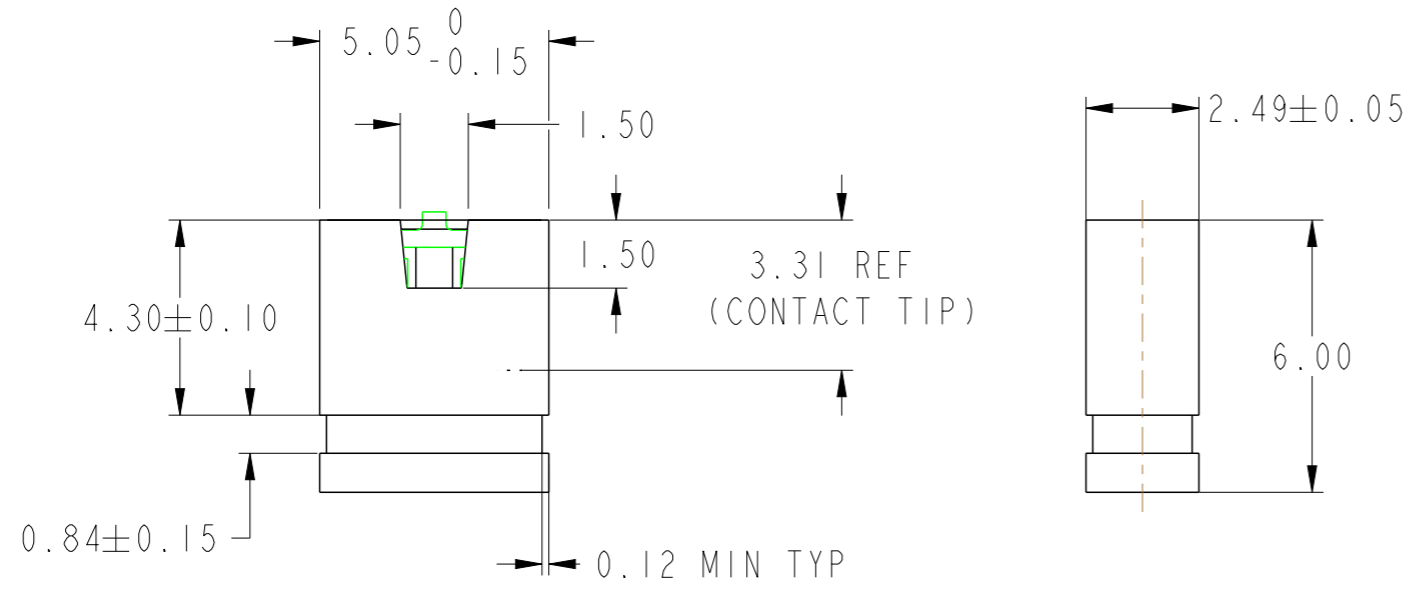

spec ref	dr	Louis Ng	2010/10/11	projection	MM	size	A3	scale	6:1
tolerance std	eng	Andrew Yong	2011/02/10	\oplus - \square	← →	ecn no	ELX-S-002821-1	rel level	Released
ISO 406 ISO 1101	chr	-	-						
surface \checkmark	appr	-	-	JUMPER		dwg no	63429	rev	G
ISO 1302	linear	0.X	±0.35	www.fci.com		cat. no.	-	PRODUCT - CUSTOMER DRW	sheet 1 of 1
	angular	A	±3°						

Copyright FCI. FCI