

HC/49US (AT49) 3RD LEAD CASE-GROUNDED SMD LOW PROFILE CRYSTAL



11.4 x 4.7 x 4.2mm

ABLSG



RoHS
Compliant

Moisture Sensitivity Level (MSL) – This product is Hermetically Sealed and not Moisture Sensitive - MSL = N/A: Not Applicable

FEATURES:

- 3rd Lead is Grounded, Ideal for EMI Sensitive Applications
- IR-reflow capable
- Low height reduced to 4.2mm
- Tight stability & extended temperature available

APPLICATIONS:

- EMI sensitive applications
- Computers, Modems, Microprocessors
- Medical Electronics
- Wireless Applications

STANDARD SPECIFICATIONS:

PARAMETERS	
ABRACON P/N	ABLSG Series
Frequency	3.579545 MHz to 75 MHz
Operation Mode	AT cut (Fundamental or 3rd OT) or BT cut 3.579545MHz - 24.0MHz (Fundamental: Standard) 24.01 - 75.00MHz (3rd- Overtone: Standard) 24.01MHz - 50.00MHz (Fund. AT or BT: Please specify. See options)
Operating Temperature	0°C to + 70°C (see options)
Storage Temperature	- 55°C to + 125°C
Frequency Tolerance	± 50 ppm max. (see options)
Frequency Stability over the Operating Temp. (Ref to +25°C)	± 50 ppm max. (see options)
Equivalent Series Resistance	See Table 1
Shunt Capacitance C ₀	7pF max.
Load Capacitance C _L	18pF (see options)
Drive Level	1 mW max., 100µW typical
Aging at 25°C Per Year	± 5ppm max.
Insulation Resistance	500 MΩ min at 100Vdc ± 15V
Spurious Responses:	-3dB max.
Drive level dependency (DLD)	From 1µW to 500µW (minimum 7 points tested)

TABLE 1: ESR

FREQUENCY (MHz)	ESR (Ω)
3.579 - 4.999 (Fund.)	180
5.000 - 5.999 (Fund.)	120
6.000 - 7.999 (Fund.)	100
8.000 - 8.999 (Fund.)	80
9.000 - 9.999 (Fund.)	60
10.000 - 15.999 (Fund.)	50
16.000 - 50.000 (Fund.)	40
24.01 - 31.999 (3rd O/T)	100
32.000 - 70.00 (3rd O/T)	80

OPTIONS & PART IDENTIFICATION:

(Left blank if standard)

ABLSG - MHz - - R - - - - - -

Frequency in MHz
e.g. 3.579545MHz
14.31818MHz
26.000MHz

Load Capacitance
Please specify CL in pF or S for Series (8 to 33pF)
Please contact ABRACON for other values

ESR
Specify a value in Ω

Operating Temp.
A: -10°C ~ +60°C
B: -20°C ~ +70°C
C: -30°C ~ +70°C
N: -30°C ~ +85°C
D: -40°C ~ +85°C
J(**): -40°C to +105°C
K(**): -40°C to +125°C
L(**): -55°C to +125°C

Freq. Tolerance
H5: ± 5 ppm
1: ± 10 ppm
7: ± 15 ppm
2: ± 20 ppm
3: ± 25 ppm
4: ± 30 ppm

Freq. Stability
U: ± 10 ppm (*)
G: ± 15 ppm (**)
X: ± 20 ppm
W: ± 25 ppm
Y: ± 30 ppm
H: ± 35 ppm
Q: ± 100 ppm (****)
R: ± 150 ppm

Packaging
Blank: Bulk
T: Tape & Reel

Mode
F: Fund.AT for >24MHz
FB: Fund.BT for >24MHz

- * 10 to +60C only.
- ** Option A, E, B, and 0 to +70C only.
- *** Frequency stability ±50ppm, ±100ppm, ±150ppm only.
Contact ABRACON for tighter frequency or stability requirement.
- **** For Fundamental BT, frequency stability ±100ppm max. at 10°C to +60°C only.

ABRACON IS
ISO9001:2008
CERTIFIED

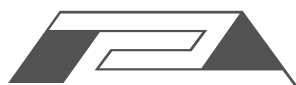

ABRACON
CORPORATION

Visit www.abracon.com for Terms & Conditions of Sale **Revised: 08.20.10**
30332 Esperanza, Rancho Santa Margarita, California 92688
tel 949-546-8000 | fax 949-546-8001 | www.abracon.com

HC/49US (AT49) 3RD LEAD CASE-GROUNDED SMD LOW PROFILE CRYSTAL



11.4 x 4.7 x 4.2mm

ABLSG



RoHS
Compliant

OUTLINE DRAWING:

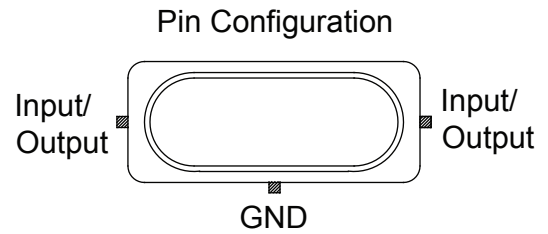
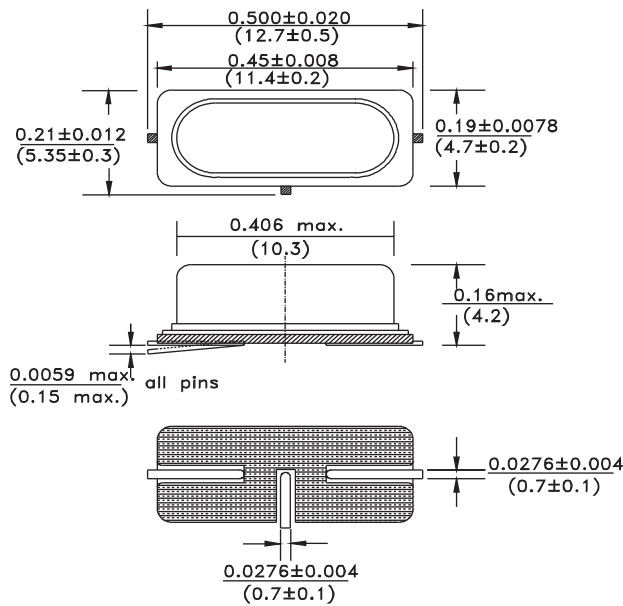

Recommended land pattern

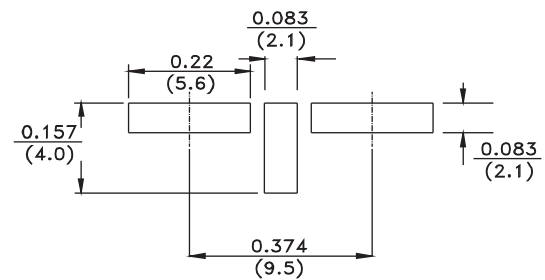

TAPE & REEL:

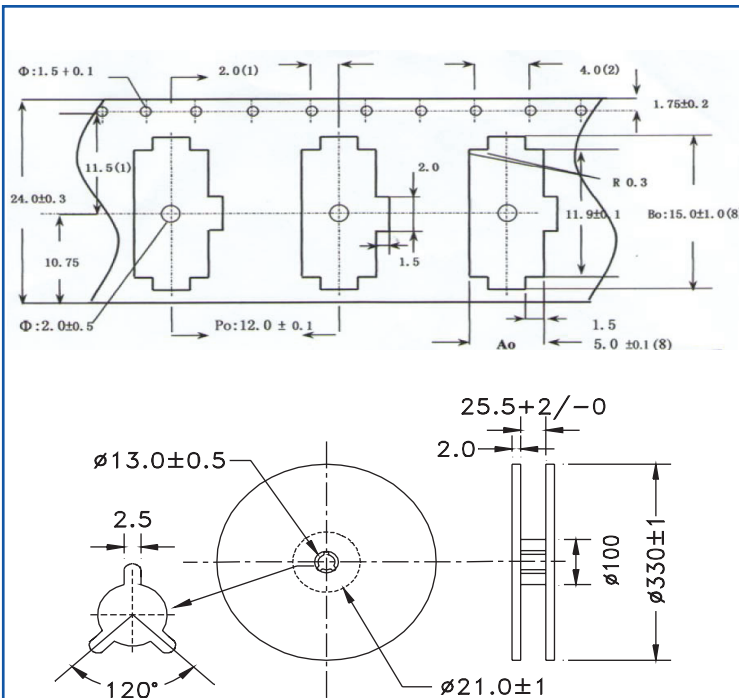

Dimensions: mm

REFLOW PROFILE:

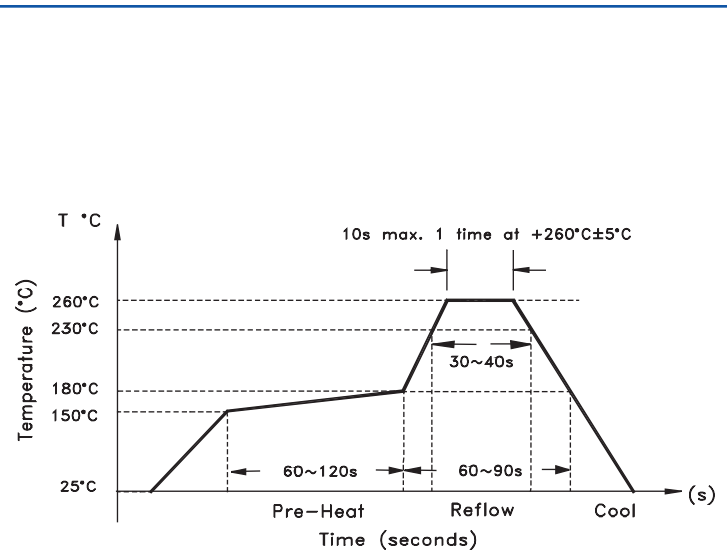

ATTENTION: Abracon Corporation's products are COTS – Commercial-Off-The-Shelf products; suitable for Commercial, Industrial and, where designated, Automotive Applications. Abracon's products are not specifically designed for Military, Aviation, Aerospace, Life-dependant Medical applications or any application requiring high reliability where component failure could result in loss of life and/or property. For applications requiring high reliability and/or presenting an extreme operating environment, written consent and authorization from Abracon Corporation is required. Please contact Abracon Corporation for more information.

ABRACON IS
ISO9001:2008
CERTIFIED



Visit www.abracon.com for Terms & Conditions of Sale **Revised: 08.20.10**
30332 Esperanza, Rancho Santa Margarita, California 92688
tel 949-546-8000 | fax 949-546-8001 | www.abracon.com